

**Engineering progress
Enhancing lives**

**RAUVISIO innara
and RAUVISIO
innara fire.protect**

Technical information



This Technical Information document on RAUVISIO innara and RAUVISIO innara fire.protect (fp) is valid from September 2023.



References to RAUVISIO innara in this document also refer to the RAUVISIO innara fire.protect (fp) variant. This approach improves readability and reduces duplication.

You can download our current technical documents from www.rehau.com/TI.

All dimensions and weights are reference values. Subject to errors and modifications.

Contents

01	Information and safety information	04
02	RAUVISIO innara and innara fire.protect (fp)	06
02.01	Product description	06
02.02	Range of application	07
02.03	Product advantages	07
03	Transport, packaging and storage	08
03.01	Transport and loading information	08
03.02	Documents for material warranty	08
03.03	Packaging	08
03.04	Internal transport and storage	09
04	Prior to processing	10
04.01	Unpacking	10
04.02	Checking the boards	10
04.03	Conditioning	10
05	Processing of RAUVISIO innara	11
05.01	Proper handling of RAUVISIO boards	11
05.02	Mechanical processing of RAUVISIO innara	11
05.02.01	Cutting RAUVISIO innara to size	12
05.02.02	Chamfer processing on stationary CNC machines and portable routers	13
05.02.03	Drilling	13
06	Machining on the construction site	14
06.01	Sawing	14
06.01.01	Circular saw	14
06.01.02	Jigsaw	14
06.02	Installing chamfers	14
06.03	Drilling	15
06.04	Adhesion	15
06.04.01	Adhesion of RAUVISIO innara	15
06.05	Grouting RAUVISIO innara	16
06.05.01	Adhesion of RAUVISIO innara fp	16
06.06	Transitions between RAUVISIO innara panels	17
07	Applications and installation instructions	18
07.01	RAUVISIO innara as a splashback	18
07.02	Bathroom and shower wall paneling	19
07.03	RAUVISIO innara as decorative wall cladding	20
07.04	RAUVISIO innara fp as fire protection	20
08	Technical data	21
09	Installation guidelines – Summary	25
10	Care and usage instructions for end users	26

01 Information and safety information

Validity

This Technical Information is valid worldwide.

Currentness of Technical Information

For your safety and to ensure the correct use of our products, please check at regular intervals whether a new version of this Technical Information is already available. You can obtain the latest version of the document from your local retailer, your REHAU sales office or at www.rehau.com/TI.

Pictograms and logos



Safety notice



Important information



The advantages for you

Intended use

REHAU RAUVISIO products may only be planned, processed and installed in accordance with this Technical Information document. Any other use is deemed to be outside the scope of intended use and therefore is not permitted.

Suitability of the material

Please read the latest Technical Information before processing, installing and using RAUVISIO innara and RAUVISIO innara fp. Our Technical Information is based on empirical values and knowledge acquired up to the time of printing. The dissemination of this information does not comprise any assurance of the properties of the products described. No explicit or implicit guarantee may be derived from it.

The information does not release the fabricator/buyer from their obligation to check that the material is suitable for the intended purpose before processing.

Disclosure of information

Make sure that everyone involved has access to the necessary information and notes on RAUVISIO innara and RAUVISIO innara fp at all times. The care and usage instructions must be made available to the end customer, either by you or by your customers.

Processing instructions

Please observe the notes provided on the packaging, accessories and installation instructions as well as the notes enclosed with the goods. Keep the usage instructions safe and have them to hand. If you do not understand the usage instructions or they are unclear to you, contact your REHAU sales office.

Relevant regulations and safety equipment

All applicable safety and environmental regulations as well as the regulations of the trade supervisory center and professional association must be observed. These regulations always take precedence over the information and notes in the Technical Information document.

Use appropriate personal protective equipment during processing, e.g.:

- Gloves
- Protective goggles
- Ear protection
- Dust mask

Work equipment

Always observe the manufacturer's information when using equipment. Flammable equipment must only be stored in safe, well-ventilated places.

Ventilation during machine processing

General precautions

- Inhalation: if you experience health problems, seek fresh air and consult a doctor if necessary.
- Skin contact: rinse skin with water. If skin irritation persists, consult a doctor.
- Eye contact: do not rub. Rinse immediately with water.
- Ensure good ventilation and extraction around the processing machines.

Disposal

The products RAUVISIO innara and RAUVISIO innara fp are harmless to the environment. The dust generated during processing is non-toxic. Reduce the dust concentration using suitable protective measures, such as an extraction system or a dust mask. Dust from RAUVISIO innara and RAUVISIO innara fp does not pose a specific explosion hazard.

Disposal code in accordance with the waste category ordinance

Disposal of RAUVISIO innara or RAUVISIO innara fp

- Disposal code 170101 Concrete
- Disposal code 170103 Tiles and ceramics

Fire behavior

Due to its composition, RAUVISIO innara fp is non-flammable, does not melt and does not produce harmful smoke gases in the event of a fire.

Construction material class according to EN 13501-1: A2-s1, d0 (non-combustible).

Fire-fighting

Suitable extinguishing agents for fire-fighting include:

- Water spray
- Foam
- CO₂
- Extinguishing powder

A water jet is not suitable for fire-fighting.

When fire-fighting, wear suitable protective clothing and if necessary standalone breathing apparatus.

02 RAUVISIO innara and innara fire.protect (fp)

02.01 Product description

RAUVISIO innara combines a high-quality natural look with the beneficial properties of a mineral fiber material to give you maximum flexibility when creating splashbacks and wall coverings. Whether in kitchens, bathrooms or living areas, natural materials like ceramic and stone are today used in a wide range of applications.

REHAU RAUVISIO innara gives you maximum flexibility when creating decorative and functional wall applications, such as kitchen splashbacks, shower backwalls, and wall-mounted modules in bathrooms. RAUVISIO innara is also used as wall cladding in areas subject to stringent demands, such as hospitals, retirement and nursing homes, kindergartens, and schools.

RAUVISIO innara fp goes one step further. The certified composite system of panels and adhesive meets the highest standards of safety and fire protection. It has been tested according to EN 13501-1 and certified with **A2-s1, d0**.

The combination of specially developed fire protection adhesive RAUBOND A1 114 with our special RAUVISIO innara fp panels guarantee the following properties:

- Non-combustible
- No smoke development
- No dripping while burning

Product structure

RAUVISIO innara is based on a digitally printed and painted mineral fiber board consisting of the individual components shown below.

Lacquer layer:

- Scratch- and chemical-resistant, gloss level
- UV-resistant

Decorative digital print layer:

- Coloring with or without design

Primer:

- Preparation for digital print

Mineral panel 4 mm thick:

- Non-combustible substrate material

Primer:

- Bonds with the wall

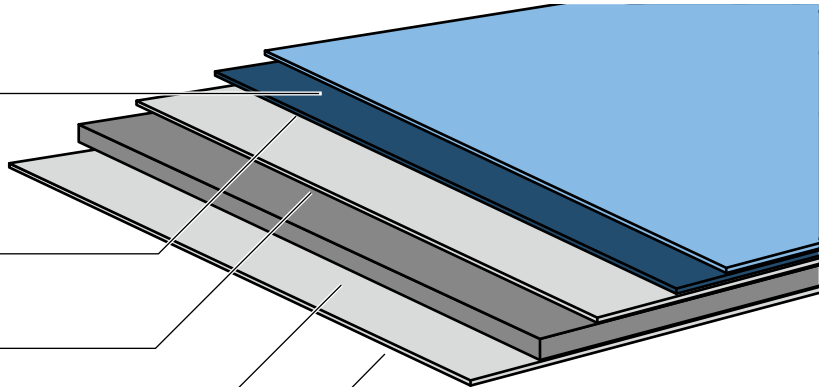

02.02 Range of application

RAUVISIO innara is designed for vertical indoor use. Horizontal application can only be approved after prior consultation with the REHAU Technical Applications Department.

Read the material properties listed in the technical data sheet for the respective application. Pay particular attention to the thermal, mechanical and physical properties, and evaluate the material's suitability for the respective application. The customer is responsible for the risk assessment and approval process.

If you have any questions, please contact the REHAU Application Engineering Department.

02.03 Product advantages



RAUVISIO innara has the following advantages:

- Purely natural product (meets criteria of the Blue Angel quality seal)
- Hygienic surface, easy to clean
- 100% waterproof
- Resistant to fire embers
- Photostable
- Excellent scratch resistance
- High impact strength
- Resistant to breakage
- Very low thermal expansion
- Breathable (absorbs moisture from the environment and releases it over time)
- Suitable for wall panel heating
- Highly resistant to acids and alkalis
- Flexible sawing and drilling with woodworking machines
- Low weight
- Suitable for construction sites – make alterations on site
- Variety of digital print designs



RAUVISIO innara fp has the following advantages:

- All benefits listed for RAUVISIO innara
- Fire protection system test: panel and adhesive are A2-s1-d0 certified (according to EN 13501-1)
- Non-combustible
- No smoke development
- No dripping while burning

03 Transport, packaging and storage

03.01 Transport and loading information



When the goods arrive, check the exterior packaging for damage immediately:

- If damage has occurred, open the packaging in the presence of the freight carrier and record the damage to the goods.
 - The shipping company driver must confirm this with their name, shipping company name, date, and signature.
 - Report any damage to the carrier within 24 hours
- In the event of a failure to comply with this, the freight carrier's insurance company will not accept liability!
-

Delivery

As they must be kept flat, the panels and laminates are shipped either on squared timbers or pallets, depending on the shipping method.

- Upon delivery, unload the pallets using a forklift or suitable lifting equipment.
- If suitable lifting equipment is not available, the panels must be unloaded individually, manually and upright by two people. Use suitable aids for handling, e.g.: suction lifters, lever handles, and panel transporters. The panels must not get dirty or be subjected to mechanical stress.
- Because of the risk of breakage, do not transport individual boards horizontally. Rather, stand them upright from the stack or a firm base and transport them vertically.
- When transporting multiple RAUVISIO innara panels horizontally, the panels must not bend.
- Beware of the risk of cuts.
Use appropriate personal protective equipment when unloading, e.g. gloves.

03.02 Documents for material warranty

Delivery notes and shipping labels should be retained to aid batch traceability in the event of a technical issue. This must be given to the REHAU sales office in the event of a complaint.

03.03 Packaging



Ensure surfaces and corners are protected from dirt and damage. Protect surfaces with a foam fleece, and protect edges and corners with foam blocks, angled pieces or strong cardboard corners.

Avoid ingress of dirt between the panels when moving, picking and processing. Remove any dirt immediately. Failure to do so may result in dirt causing pressure marks on the laminate surfaces due to the weight of the panels.

03.04 Internal transport and storage

Inter-company transport

Manufacturer recommendation

RAUVISIO innara must be transported lying flat and supported throughout.

Position the panels vertically and separated on suitable trolleys.

Alternatively:

Stack the workpieces in layers with clean and padded carton/foam material inserted in-between each layer on a pallet.



Please note the information in Chapter "03.01 Transport and loading information" on page 08 and in Chapter "03.03 Packaging" on page 08.

Storage

Improper storage voids the warranty against any signs of warping. RAUVISIO innara is delivered on pallets or squared timbers with appropriate protective boards to cover them. The packaging units (PU) are stackable.



Due to their own weight, no more than 4 units may be stored on top of each other.

The packaging units must be protected against damage, high temperatures and humidity fluctuations, as well as high UV levels from artificial lighting and direct sunlight.

If this is no longer present, at least a level and properly prepared 5-batten storage system is required (see sketch). This prevents the panels from bending or warping.

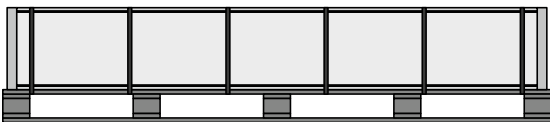

Fig. 03-1 Pallet packaging

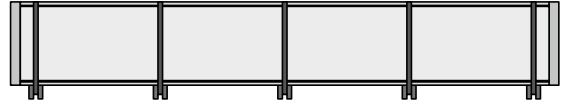

Fig. 03-2 5-batten storage

Observe the permissible environmental conditions for storage:

- Room temperature: 15 °C–25 °C
- Relative humidity: 30%–70%



Before processing, please read the notes under 04.01 Unpacking in Chapter 04.

After removing a partial quantity, make sure that the cover board is replaced on the goods before they are returned to storage to prevent contamination and irregular levels of temperature and moisture. This can prevent warping effects and surface damage caused by drafts or heating air.

04 Prior to processing

04.01 Unpacking

Prior to opening packaging units, the panels must be allowed to acclimatize to room temperature for at least 48 hours, depending on the time of year.



Make sure the surface is not damaged by sharp objects or during moving. Use suitable lifting equipment to separate the panels.

Open the packaging using packaging scissors. Do not use a sharp blade!

1. Cut the packaging tape.
2. Cut the protective film away from sheets.
3. Carefully lift the uppermost cover board vertically upwards and without displacing it. This should be done by two people using four vacuum lifting pads. For individual packages, carefully remove the box.
4. Avoid ingress of dirt between the individual panels and remove any dirt immediately upon discovery.

04.02 Checking the boards

Before further processing, check for the following:

- External damage, such as cracks or marks
- Surface damage or defects
- Planarity
- Surface tension on the back of the panel
- Color consistency within the production batch

RAUVISIO innara surfaces are always delivered with foam fleece between each panel. Despite this foam fleece, slight scratches or pressure/defects in the laminates are possible upon delivery. There may be slight scratches, dents or defects in the laminates. These cannot be entirely due to the production technology and do not constitute a direct reason for complaint.

Where an order utilizes multiple laminate sheets, it is recommended that only laminate sheets with the same batch number are used. Uniformity of color across production batches must be checked prior to processing.

Compare panels to check the uniformity of color in daylight conditions but not in bright/dazzling/direct sunlight.



REHAU cannot cover the costs incurred during this test or any subsequent costs of processing defective goods.

04.03 Conditioning



RAUVISIO innara and all other materials being processed, e.g. edgeband, must be acclimatized at room temperature (min. 18 °C) for a duration of at least 48 hours prior to processing. Processing is also carried out at room temperature.

If there is insufficient acclimatization of the laminate on the inside due to the stack size, the dwell time must be adjusted accordingly.

05 Processing of RAUVISIO innara

05.01 Proper handling of RAUVISIO boards

Placing the boards on the machine table

- The machine table must be of sufficient size
- Must not have any sharp edges
- Must be thoroughly cleaned.

Alternatively:

- Cover the machine table with a clean base (wooden board, carton, etc.).

Cutting the panels

REHAU recommends using the nesting cutting method when cutting the panels to size.

If cutting the panels to size using a saw, read the notes on positioning the panels on the machine table (see above). Use a scorer if cutting the panels to size using a saw.

Between the processing steps

After milling/sawing, all residue must be removed and all surfaces cleaned.



Please read the transport and loading information in Chapter 03 Transport, packaging and storage, especially Chapter 03.04 Internal transport and storage.

Drilling and milling

To avoid damaging the surfaces, chips must be safely removed when drilling and milling, e.g. by extraction.

Packing the workpieces

Stack the workpieces in layers on pallets with a clean and pliable interlay of cardboard or foam between the layers.

Use a transport lock to prevent damage due to slipping or similar.

05.02 Mechanical processing of RAUVISIO innara

We recommend using diamond-tipped, sharp woodworking tools for optimal processing.

When machining RAUVISIO innara panels by sawing, milling, chamfering and drilling, it is very important to select suitable tools and pay attention to the machining parameters. Choosing the wrong tools or operating conditions can lead to tearing, buckling, excessive heating, premature tool wear, or damage.

REHAU recommends checking the cut quality by carrying out machining tests on test samples.

Optimal machine parameters, tool configurations, and cutting speeds must be established for every application using a series of samples prior to production. If necessary, please contact REHAU Technical Applications Department and/or your tool manufacturer.

REHAU recommends using the tools at low cutting speeds to reduce dust generation and tool wear during machining.

05.02.01 Cutting RAUVISIO innara to size

To ensure good cutting results, please observe the following:

- Good side / design side up
- Correct saw blade projection
- Adjust the rotational speed and number of teeth to suit the feed speed
- Use a scoring saw for clean cuts on the underside of the panel
- Cutting speed
- Tooth shape
- Tooth pitch

05.02.01.01 Sizing saws

REHAU recommends using saw blades with a high number of teeth for good machining quality.

The best cutting quality is achieved with the following tooth shape combination:

- DP circular saw blade with tooth shape HR (hollow back tooth)
- DP circular saw blade with tooth shape HR-FA (hollow back tooth with chamfer)
- DP circular saw blade with tooth shape DZ/TR (pointed tooth / hollow tooth)
- DP circular saw blade with tooth shape TR/TR (trapezoidal tooth / trapezoidal tooth)
- DP circular saw blade with FZ/TR tooth shape (flat tooth / trapezoidal tooth)

Saw blades with hollow teeth produce an inferior cut quality (chips in the top layer). Minimal chipping can usually be smoothed with fine abrasive paper.

Operating parameters:

Optimal saw blade projection P	5–40 mm
Recommended cutting speed	65–75 m/s
Feed per tooth fz	0.02–0.12 mm

05.02.01.02 Panel sizing saws

Panel sizing systems produce excellent cutting results and have long service lives.

REHAU recommends DP panel sizing circular saw blades with trapezoidal tooth / trapezoidal tooth (TR/TR) tooth shapes.

Alternatively, flat tooth / trapezoidal tooth (FZ/TR) saws can be used. The recommended feed per tooth (fz) is in the range of 0.06–0.07 mm. The maximum feed per tooth is $fz = 0.096$ mm and must not be exceeded.

Operating parameters:

Rotational speed n	3,600 rpm
Feed vf	20 m/min
Projection P	35 mm
Feed per tooth fz	0.07 mm

The saw enters on the design side of the panel. Setting the correct saw blade projection ensures excellent cutting results. The saw blade projection depends on the diameter and should be between 20 mm and 28 mm.

The recommended cutting speed is 60–90 m/sec. Select the upper value for DP-tipped circular saw blades. The target is a feed per tooth of 0.07–0.08 mm.

Saw blade diameter	Projection
D = 300 mm	P = approx. 20 mm
D = 350 mm	P = approx. 25 mm
D = 400 mm	P = approx. 25 mm
D = 450 mm	P = approx. 30 mm

05.02.01.03 Cutters for straightline edgebanders

Industrial panel sizing on continuous systems is carried out using diamond-tipped tools. It is advisable to use hogging tools that generate little friction and low cutting pressure. When sizing panels using cutting tools, excellent results can be achieved with double cutters.

Operating parameters:

Cutting speed	80 m/s
Rotational speed n	6000 rpm
Diameter D	250 mm

Select suitable operating parameters and numbers of cutter teeth to ensure that the tooth feed is within the following range:

Feed per tooth fz	0.15–0.25 mm
-------------------	--------------

Small amounts of chipping must be expected when using other types of cutter, but this can sometimes be remedied by touching up the joint.

05.02.01.04 Machining on stationary CNC machines

For machining and long tool life on CNC router machines and machining centers, milling work should be carried out using diamond-tipped end mills with alternating axis angles. Routers with an axis angle of 30° are sufficient.

Panel sizing tools with a higher number of teeth than standard tools tend to create better quality cuts and have longer service lives. REHAU recommends pre-milling the workpieces to lower the chip-removal rate (between 0.5 and 2.0 mm) and reduce tool wear during FINISH machining.

Recommended feed per tooth fz	0.2–0.34 mm
-------------------------------	-------------

Example 1: D = 20 mm/Z = 2+2:

Rotational speed	18,000 rpm
Feed	7 m/min (fz = 0.2 mm)

or:

Rotational speed	24,000 rpm
Feed	10 m/min (fz = 0.2 mm)

Example 2: D = 48 mm/Z = 4+2+4:

Rotational speed	18,000 rpm
Feed	25 m/min (fz = 0.34 mm)

05.02.01.05 Nesting

Diamond-tipped end mills with alternating axis angles are required for machining.

Example D = 12 mm/Z = 3+3:

Rotational speed	24,000 rpm
Feed	15 m/min (fz = 0.2 mm)

05.02.02 Chamfer processing on stationary CNC machines and portable routers

Diamond-tipped edge finishing tools, such as 45° chamfer cutters, flush cutters or corresponding profile cutters can be used in CNC router machines and machining centers to machine 45° chamfers on RAUVISIO innara panels.

To guarantee good milling results, it is advisable to use well-balanced tools with high concentricity, e.g. by using centering interfaces such as HST tool holders. The tooth feed (fz) should be within the following range during machining:

Tooth feed fz	0.25–0.50 mm
---------------	--------------

For example, a 45° chamfer can be milled on mineral fiber board using a profiled groove cutter when performing climb milling processes. The tooth feed (fz) should be within the following range when performing climb milling processes:

Tooth feed fz	0.05–0.12 mm
---------------	--------------

Diamond-tipped chamfer mills or indexable insert mills with a stop ring should be used when machining 45° chamfers using portable routers. When working with portable routers, a manual feed tool must only be used when performing conventional milling processes.

05.02.03 Drilling

Solid carbide, spiral or dowel hole drills are preferred for drilling tasks.

Operating parameters:

Rotational speed	5000 rpm
Feed	1.5 m/min
Drill mode	S-S (fast-fast)

06 Machining on the construction site

06.01 Sawing



RAUVISIO innara can be cut to the desired dimensions using a circular saw and guide rail. Contours and fine cut-outs can be made with a jigsaw.

06.01.01 Circular saw



The quality of the cut edge depends on the tooth shape, the number of teeth on the saw blade and the cutting speed.

REHAU recommends the following procedure for machining RAUVISIO innara using a circular saw:

- Always cut RAUVISIO innara from the good side to avoid chipping the good side.
- Use a diamond-tipped circular saw blade with a high number of teeth and tooth shape HR (hollow back tooth), e.g. diamond-tipped circular saw blade 160 x 2.2 x 20 Z = 30, HR.
- Select a high speed and keep the rake angle as negative as possible.
- A smooth, slow manual feed creates the best results.

06.01.02 Jigsaw



To achieve good results using a jigsaw, REHAU recommends the following procedure:

- Always cut RAUVISIO innara from the good side to avoid chipping the good side.
- Use a bi-metal saw blade with a tooth pitch of 3.0 mm.
- It is advisable to cut without reciprocating action.
- For cut-outs within panels, it is advisable to cut relief holes to relieve any tension in the material.

06.02 Installing chamfers

We advise only breaking the edges gently. This is best carried out using fine abrasive paper on a sanding block.

06.03 Drilling



Flexible on-site holes can be drilled easily. REHAU recommends using the following procedure for drilling:

- Preferably use diamond-tipped, solid carbide twist, or dowel hole drills.
- Drill with slight pressure and a matching feed into the material.
- When using hole saws, sharp saw teeth with slightly blunt centring drills should be used.
- Always drill RAUVISIO innara from the good side to avoid creating chips when drilling through from the back
- Always use a suitable substrate, such as MDF or chipboard.



06.04 Adhesion

06.04.01 Adhesion of RAUVISIO innara

A 1-component PU hybrid adhesive is recommended for bonding, e.g. SikaFlex AT connection. Follow the adhesive manufacturer's notes when bonding.

1. Apply the adhesive in beads using a caulking gun.



2. Spread the applied adhesive over the entire surface using a 4 mm notched spatula.

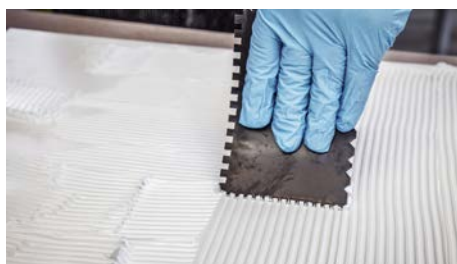

3. Align the panels and press them evenly onto the wall all over.



06.05 Grouting RAUVISIO innara

1. Grout the joints with a silicone grout in a matching color



2. Smooth the silicone.



06.05.01 Adhesion of RAUVISIO innara fp

1. Apply fire protection adhesive RAUBOND A1 114 from a bucket (16 kg) to the wall or panel. The application rate is 2 kg per square meter.
2. Smooth the entire surface of the adhesive using a 4 x 4 mm notched spatula. The subsurface must be completely covered.
3. If the initial adhesion of the RAUBOND A1 adhesive is insufficient to hold the panel in the desired position, the panel can be supported with shims. Up to 60 g/m² of Sikaflex AT connection mounting adhesive can be applied to the underside of the panel to increase initial adhesion.



When using the Sikaflex AT connection mounting adhesive, make sure that the Sikaflex mounting adhesive is completely surrounded by the fire protection adhesive.

Application example for the two adhesives:

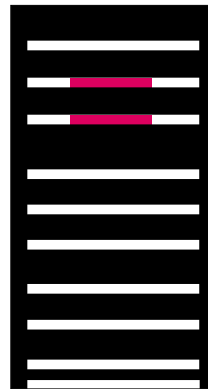

□ RAUBOND A1 114
2 kg/m²

■ Sikaflex AT
connection 60 g/m²

06.06 Transitions between RAUVISIO innara panels

Joint in detail

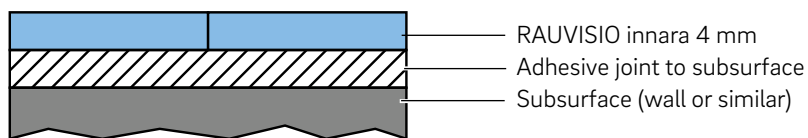

Outside corner in detail

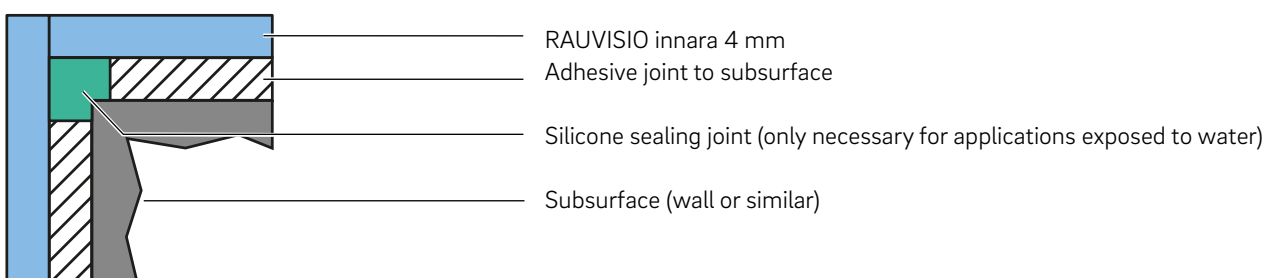

Inside corner in detail

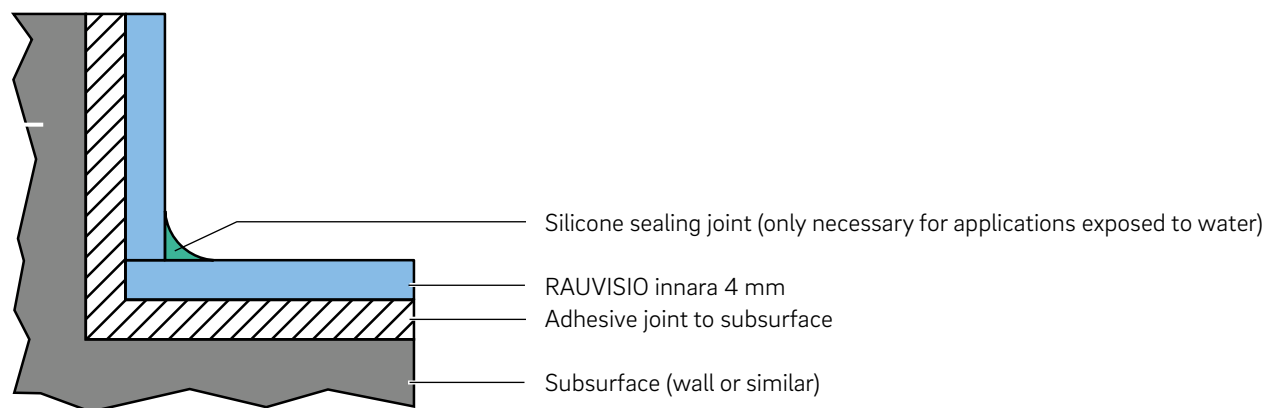

Further options

Profiles:
 REHAU supplies suitable profiles for every type of connection.

Grout:
 If joints are desired between the panels, these can be filled with grout. REHAU recommends using Ardex G10 grout.

Profile	Connection
Joining profile	2 panels next to one another
Internal, external corner profiles	2 panels connected at 90°
End profile	For finishing the edge of a panel



When using our panels as a fire protection solution, Ardex G10 grout must be used as this is tested and certified in the system.

07 Applications and installation instructions

RAUVISIO innara is designed for vertical applications indoors. A horizontal application is performed as a matter of principle on the user's own authority. Consultation with REHAU's Applications Engineering Department may be necessary.

07.01 RAUVISIO innara as a splashback

RAUVISIO innara is digitally printed. To prevent damage to the surface, the panels must be installed a sufficient distance away from hobs depending on the type of hob and the resulting radiant temperatures.

Cooking range	Minimum distance
Induction, ceramic, cast iron	≥ 50 mm
Gas	≥ 200 mm

In the case of improper use, such as if the hobs are not or only partially covered when switched on for long periods or if there is direct contact with hot pots and pans, etc., temperature damage can occur to the surface.

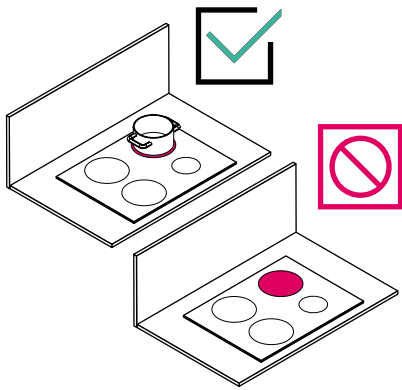

Proper and improper use

Splashes of fat that hit the surface when in proper use do not damage the surface and can be removed without any residue.

We recommend using a tested 1-component PU hybrid adhesive (Sikaflex AT connection) for the full-surface bonding of RAUVISIO innara panels to back walls. To do so, the bonding substrates must be level, clean and free of grease. It is also important to read and observe the adhesive manufacturer's notes.

Partially, double-sided adhesive tape can be used to mount it to the wall. Press the panels onto the wall with sufficient force to ensure that the maximum gap of 2 mm between the panel and the wall is not exceeded and to ensure adequate adhesion.

Connecting or expansion joints are maintenance joints that need to be checked regularly and repaired as necessary.



Please note the current information provided by the German Construction Confederation (ZDB), specialist group Fachverband Fliesen und Naturstein (FFN). The information sheet "Information on the installation of liquid-processed composite seals with cladding and coverings made of tiles and panels for indoor and outdoor areas" contains important basic information about professional planning and execution. REHAU accepts no liability for damage resulting from improper or unprofessional processing. Please check whether country-specific regulations apply to the areas surrounding hobs and observe them accordingly.

07.02 Bathroom and shower wall paneling

RAUVISIO innara is suitable as a tile replacement in wet areas.

Fixing RAUVISIO innara to walls

Full-surface bonding using
4 x 4 mm notched spatula

Wall sealed in
compliance with
standards

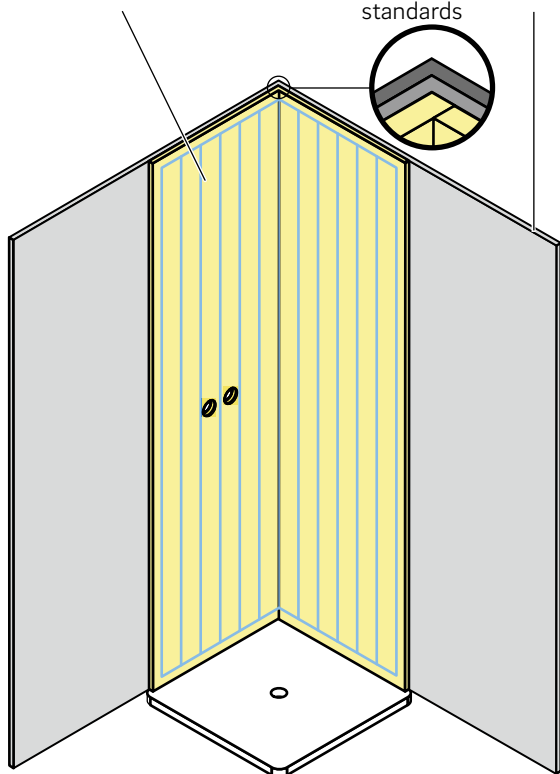

Due to joints and connection points on surfaces that are directly exposed to moisture, this requires the installation of additional sealing (sealing membranes or liquid sealants) under the wall covering. The stress classes for moisture exposure as defined in DIN 18531 must be taken into account.



REHAU expressly recommends PCI Lastogum liquid waterproofing. All other liquid sealants must be tested for adhesive suitability.

Recesses and holes must also be made 4 mm larger and sealed with silicone to prevent the ingress of moisture.

In principle, the installation instructions given in this chapter also apply to full-surface bonding with 1-component PU hybrid adhesive (Sikaflex AT connection).

Silicone jointing



Please note the current information provided by the German Construction Confederation (ZDB), specialist group Fachverband Fliesen und Naturstein (FFN). The information sheet "Information on the installation of liquid-processed composite seals with cladding and coverings made of tiles and panels for indoor and outdoor areas" contains important basic information about professional planning and execution. REHAU accepts no liability for damage resulting from improper or unprofessional processing.

Please check whether there are any country-specific regulations relating to the environment of cooking ranges and apply these accordingly.

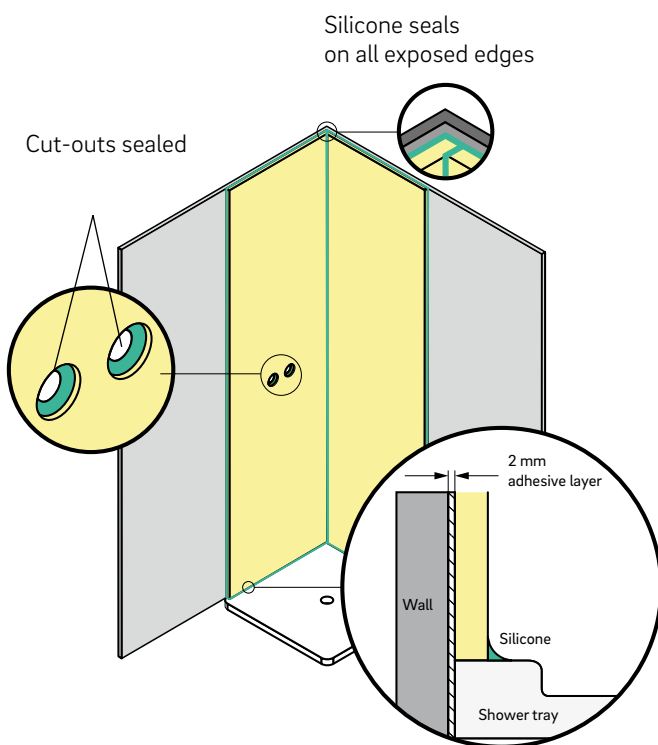

To seal the outer and abutting edges, REHAU recommends silicone grouting across all exposed edges to prevent the ingress of moisture, dirt, waterlogging and mold.

All connection joints and expansion joints must be sealed using fungicidal, neutrally cross-linked sanitary silicone.

07.03 RAUVISIO innara as decorative wall cladding

RAUVISIO innara can also be used as decorative wall cladding. Applications include cladded walls behind bed headboards or decorative elements behind shelving or TV cabinets. The cladding can also be used to cover pre-wall elements in bathrooms.

When the cladding is used as a decorative element, the wall should be load-bearing, flat, and clean. Smaller irregularities can be leveled out using Sikaflex AT connection mounting adhesive.

07.04 RAUVISIO innara fp as fire protection

RAUVISIO innara fp is a fully certified system and therefore meets the highest fire protection requirements. The composite system consisting of RAUVISIO innara fp fire protection panels and the specially developed fire protection adhesive RAUBOND A1 114 achieves building material class A2-s1, d0 according to EN 13501-1. (For bonding, see Chapter 06.05.01).

The panels can be laid end to end when covering a wall surface. They can be installed with a shadow gap of up to 3 mm or grouted using Ardex grout. The certified composite system also allows for the use of anodized aluminum profiles.

This composite system allows RAUVISIO innara fp to be used very flexibly and in a variety of ways. Thanks to its unique properties, the system guarantees reliable protection in the event of fire and is therefore ideal for use in healthcare system applications as well as in public buildings such as schools, kindergartens, shops, and restaurants. RAUVISIO innara fp panels are a natural product free from harmful substances and are therefore safe for use as wall cladding in interior design applications.

08 Technical data

Overview of RAUVISIO innara data:

Visual properties	Test standard	Requirements	Test result
Surface gloss level	DIN EN ISO 2813 (02/2015)	<ul style="list-style-type: none"> Measurement with 60° measurement 	Pale design: 9.1 Dark design: 6
Color/decorative design	AMK-MB-009, 09/2010	<ul style="list-style-type: none"> No significant changes from the master sample Uniform coverage properties / design pattern 	Fulfilled
Light fastness	DIN EN ISO 4892-2, method B (behind window glass) Assessment in line with DIN EN ISO 105 A02	<ul style="list-style-type: none"> Assessment in line with blue scale 	Level 7
		<ul style="list-style-type: none"> Assessment in line with gray scale 	Level 3
Surface	AMK-MB-009, 09/2010	<ul style="list-style-type: none"> Uniform surface, surface defects must not have a distracting effect from a distance of 0.7 m. A flawless surface cannot be produced due to the industrial manufacturing process; small defects, surface irregularities, and cavities of the same size and distribution as demonstrated by the original sample are permissible. 	Fulfilled

The following boundary conditions apply:

- | | |
|---|---------------------|
| ▪ Viewing distance | 700 mm |
| ▪ Illuminance | 1000–2000 lx |
| ▪ Angle of inclination | 30° out of vertical |
| ▪ Light source color temperature (daylight, diffuse light or D65 lamps) | 6500 K |
| ▪ Viewing time: | 20 s max. |

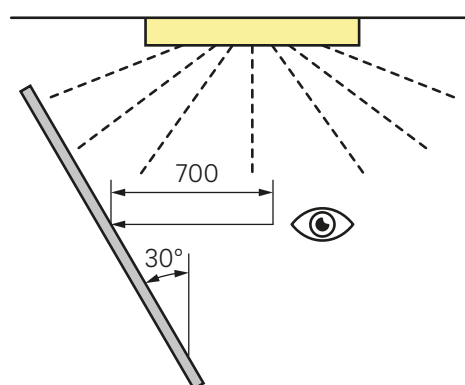

Surface and colors must be within tight tolerance limits appropriate to the application. Defined tolerance limits are color-specific and must be agreed with the customer.

Surface properties – mechanical/ physical	Test standard	Requirements	Test result
Chemical resistance ¹⁾	DIN 68861/T1	1A	1A See Substances table
Scratch resistance	DIN 68861/T4	4E	Pale design 4B
			Dark design 4D
Micro-scratch resistance	DIN CEN TS 16611 (method A/B)	Method B: class 5	Fulfilled
Performance in dry heat	68861/T7 method B	Method B: Stress group 7C / 100 °C / level 5	No mark visible
Behavior in moist heat	68861/T8 method B	Method B: Stress group 8A / 100 °C / level 5	No mark visible
Cross-hatch test	DIN EN ISO 2409	GT 0-1	GT 0
Performance in water vapor	DIN ISO 438-2	Level 5	No changes
Flexural tensile modulus ²⁾	DIN EN ISO 178	Parallel to extrusion direction	13.3 N/mm ²
		Transverse to extrusion direction	10.4 N/mm ²
Flexural strength ²⁾	DIN EN ISO 178	Parallel to extrusion direction	30.9 N/mm ²
		Transverse to extrusion direction	20 N/mm ²
Impact strength ²⁾	DIN EN ISO 179-1		3.2 kJ/m ²
Thermal coefficient of linear expansion per Kelvin temperature change ²⁾	DIN ISO 11359-2	Parallel to extrusion direction	
		-40 °C to +20 °C	12.62 µm/(m- °C)
		-10 °C to +40 °C	11.43 µm/(m- °C)
		-20 °C to +80 °C	10.42 µm/(m- °C)
		Transverse to extrusion direction	
		-40 °C to +20 °C	12.22 µm/(m- °C)
		-10 °C to +40 °C	11.69 µm/(m- °C)
		-20 °C to +80 °C	10.81 µm/(m- °C)

1) The testing of chemical resistance to DIN 68861-1 covers the substances listed in the table below; other substances have not been tested specifically and must be separately tested by the customer. Test results apply exclusively to the varnished board surface and not to mechanically exposed radii or chamfers in the milled area or on the surface.

2) RAUVISIO innara

Chemical resistance

The product is resistant to common household chemicals, substances and disinfectants. Aggressive substances acting upon the material for extended periods of time can leave residue or damage the material. The table below shows the material's chemical resistance to various substances. The user is responsible for testing the material's chemical resistance to any other substances that are not listed in this table.

Assessment according to DIN EN 12720 (07/2009) Chemical resistance rating

5	No visible change
4	Barely perceptible change in gloss or color
3	Slight change in gloss or color; the structure of the test surface is unchanged
2	Heavy marking visible; however, the structure of the test surface is largely undamaged
1	Heavy marking visible; the structure of the test surface is changed
0	Test surface severely changed or destroyed

Substances on RAUVISIO innara/innara fp

Substance	Exposure time D	Result according to DIN EN 12720 (2009-07)
Acetic acid	16 h	5
Citric acid	16 h	5
Ammonia water	16 h	5
Ethyl alcohol	16 h	5
Red wine	16 h	5
Beer	16 h	5
Cola	16 h	5
Coffee	16 h	3
Black tea	16 h	5
Blackcurrant juice	16 h	5
Evaporated milk	16 h	5
Water	16 h	5
Petrol	16 h	5
Acetone	16 h	5
Ethyl-butyl acetate	16 h	5
Butter	16 h	5
Olive oil	16 h	5
Mustard	16 h	5
Onion	16 h	5
Disinfectants	16 h	5
Cleaning agent	16 h	5
Cleaning solution	16 h	5

Product data

Product data	Test standard	RAUVISIO innara
Total panel thickness	Based on DIN EN 438-2	3.9 + 0.1–0.2 mm
Width	Based on DIN EN 438-2	1250 mm ± 5 mm
Length	Based on DIN EN 438-2	2800/2500 mm ± 5 mm
Perpendicularity	Based on DIN EN 438-2	≤ 1 mm/m
Edge defects	Based on DIN EN 438-2	15 mm
Surface weight		7 kg/m ²
Density	According to DIN EN 323	1759 g/cm ³
Waste disposal code (AVV)		Disposal code 170101 Concrete – Disposal code 170103 Tiles and ceramics

09 Installation guidelines – Summary



To avoid damage to the RAUVISIO surface due to improper handling, please observe the following instructions.

Only transport and store large size boards on pallets with level and stable base protection boards along the length (e.g. MDF 18).

Always unload / load from the short side in the center.

Do not store large-sized boards or preassembled boards in damp rooms and not directly on the ground.

Do not store large-sized boards or preassembled boards in the open air nor in areas with UV radiation sources.

Acclimatize elements prior to installation for at least 24 hours at room temperature (min. 18 °C). At delivery temperatures below 5 °C, the elements must be acclimatized on all sides for at least 48 hours.

Do not deposit any objects on large-sized boards or preassembled elements, because this could cause damage.

RAUVISIO innara is suitable for vertical applications indoors (in particular furniture fronts and backsplash applications). Special applications beyond the confirmed properties described above must be checked independently by the processor / customer or queried with and, where necessary, approved by the manufacturer.

We recommend using a 1-component PU hybrid adhesive (Sikaflex AT connection) for the full-surface bonding of RAUVISIO innara panels. To do so, the substrates to be bonded must be level, clean and free of grease. The instructions of the adhesive manufacturer must also be observed.

It is essential to use the panel and fire protection adhesive system (RAUBOND A1 114) tested and certified by REHAU for the full-surface bonding of RAUVISIO innara fire.protection panels. The substrates must be clean and free of grease before application. The quantities of adhesive to be used must be taken into account and adhered to (see usage instructions).

The adhesive must be applied to the entire surface. Expansion joints must be taken into consideration to suit the installation situation.

The acclimatized material may not be installed at temperatures < 15 °C.

All materials and components must be checked for damage or defects prior to processing/assembly.

To avoid stress cracking during processing and installation, interim storage prior to installation is allowed only in the original packaging in frost-free enclosed rooms.

Damage to the surface can be caused by strong chemical substances, e.g. strong solvents, special cleaners (e.g. drain cleaners, industrial cleaners, etc.) as well as aggressive scouring agents.

The following elements can cause scratches during cleaning: grains of sand or similar, abrasive scouring utensils/cleaning sponges, etc.

RAUVISIO innara products are NOT guaranteed to be non-slip.

Do not use sharp objects on the surface.

10 Care and usage instructions for end users



You have made a wise choice and have chosen a product made from a very high-quality and durable material.

RAUVISIO innara is a tough, impact-resistant yet lightweight mineral surface material. It is suitable for vertical indoor applications.

The homogeneous material is hygienic and resistant to fungi and bacteria.



RAUVISIO innara is easy to clean. Most dirt can be removed using water and a cleaning cloth. In addition, normal household liquid cleaners can be used to clean the surface.



RAUVISIO innara has a high-quality HardCoat finish. The surface is exceptionally resistant to scratching and abrasion, so it can withstand most normal household wear and tear.



The product is resistant to common household chemicals, substances and disinfectants. Aggressive substances acting upon the material for extended periods of time can leave residue or damage the material.



Strong solvents, special cleaners (e.g. drain cleaners, industrial cleaners), corrosive abrasive cleaners and strong chemical substances can damage the surface.

Remove persistent contamination using a soft sponge, commercially available plastics cleaner or liquid cleaner (without scouring agent).

Do not use abrasive cleaning sponges with scouring fleece (e.g. pot sponges) or brushes, as these can cause scratches if too much force is applied.

Mechanical cleaning processes, such as razor blades, knives or scrapers, should not be used as this can cause scratches and damage the abrasion-resistant coating.

This document is protected by copyright. All rights based on this are reserved. No part of this publication may be translated, reproduced or transmitted in any form or by any similar means, electronic or mechanical, photocopying, recording or otherwise, or stored in a data retrieval system.

Our verbal and written advice with regard to usage is based on years of experience and standardised assumptions and is provided to the best of our knowledge. The intended use of REHAU products is described comprehensively in the technical product information. The latest version can be viewed at www.rehau.com/TI. We have no control over the application, use or

processing of the products. Responsibility for these activities therefore remains entirely with the respective user/processor. Where claims for liability nonetheless arise, they shall be governed exclusively according to our terms and conditions, available at www.rehau.com/conditions, insofar as nothing else has been agreed upon with REHAU in writing. This shall also apply for all warranty claims, with the warranty applying to the consistent quality of our products in accordance with our specifications. Subject to technical changes.

www.rehau.com/locations

© REHAU Industries SE & Co. KG
Helmut-Wagner-Str. 1
95111 Rehau

O82603 DE/en 11.2023